



Bervic Engineering Company Pty Ltd

258 Boundary Road, Braeside, Victoria 3195 Australia
 Tel: +61 3 9587 2766 Fax: +61 3 9587 3485
 E-mail: bervic@bervic.com.au www.bervic.com.au

For fast fixing of parallel conductors use
BERVIC Split Bolt Clamps



Proudly **Made In Australia** from Australian Brass

Clamp No.			Maximum Conductor Size		Dimensions in mm (except B which is in Inches)							
Type	Plain	Electro Tinned	mm ²	Wires	A	B	C	D	E	F	G	H
A	B22	B22 T	16	7/.064	5.3	½"	10.4	30.2	7.9	11.1	17.9	6.3
B	B24	B24 T	35	7/.104	8.3	⅝"	13.2	36.5	9.5	14.3	23.2	6.3
C	B25	B25 T	70	19/.083	10.9	⅞"	17.9	44.5	9.5	22.2	27.7	7.1
D	B26	B26 T	95	19/.101	12.9	⅞"	17.9	50.8	9.5	22.2	27.7	7.1
E	B28	B28 T	185	37/.103	18.5	1¼"	23.2	66.7	9.5	25.4	42.1	7.9

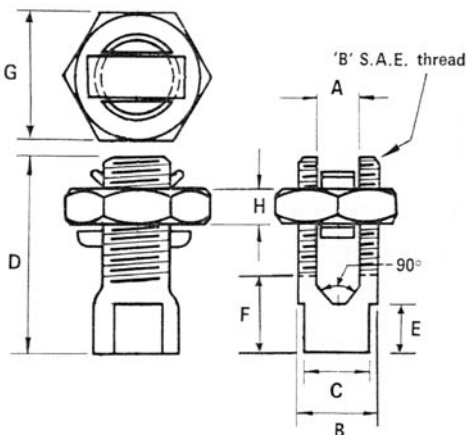

Bervic Split Bolt Clamps are made of 100% Australian Brass and comes in a plain or electro-tinned finish.

All dimensions are to Electrical Supply Association of Australia Standards (ESAAS). The **Type** number is the ESAAS reference number.

Bervic Split Bolt Clamps are supplied in sturdy cardboard cartons.

Pack size: **B22**–Qty 500, **B24**–Qty 250, **B25**–Qty 125, **B26**–Qty 100, **B28**–Qty 25



Quality Endorsed Company

ISO 9002
 Standards Australia
 Lic. No. QEC 4788